

FORFRA

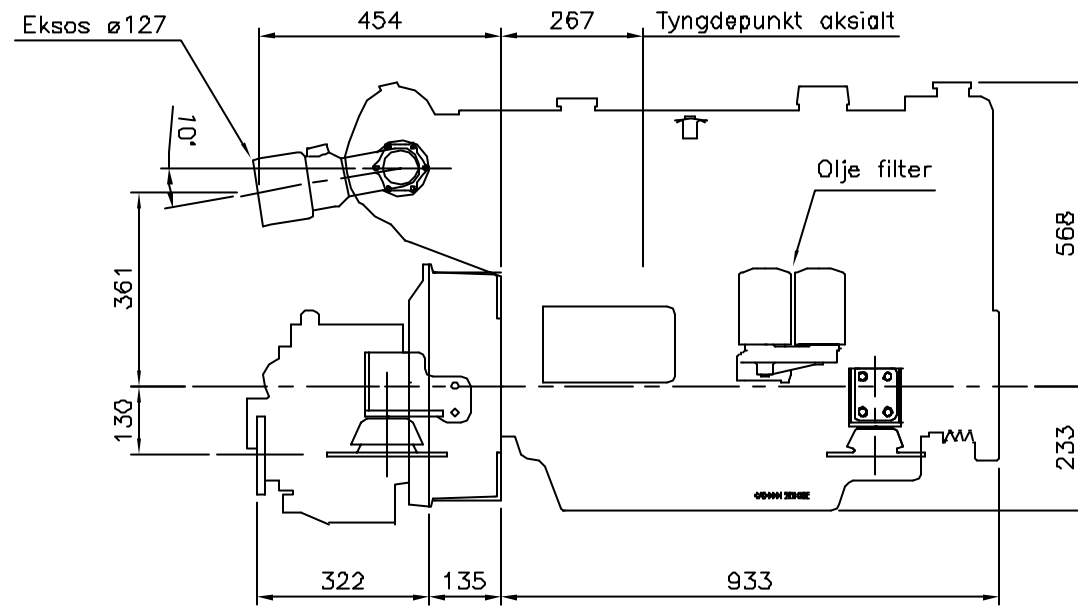

HØYRE SIDE

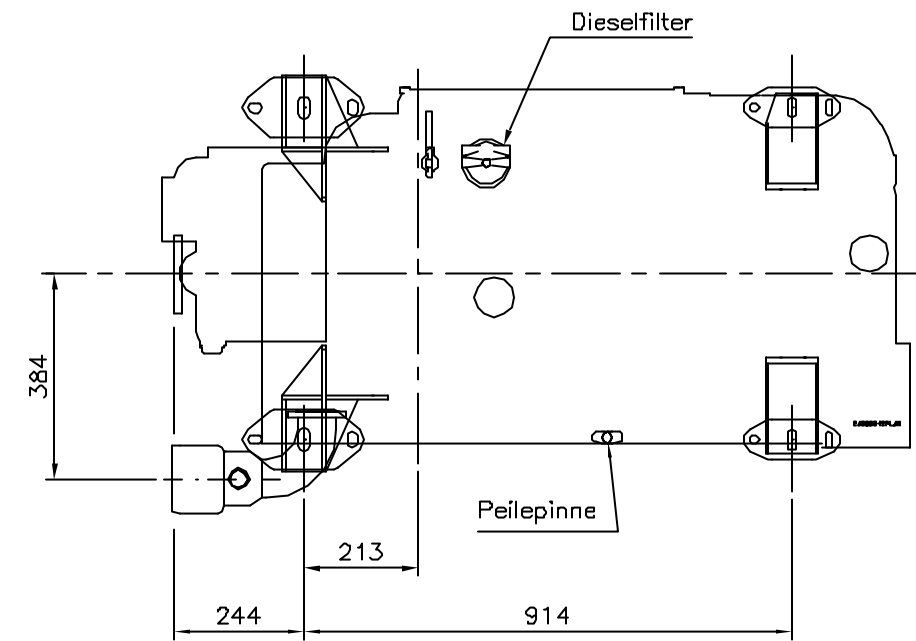

OVENFRA

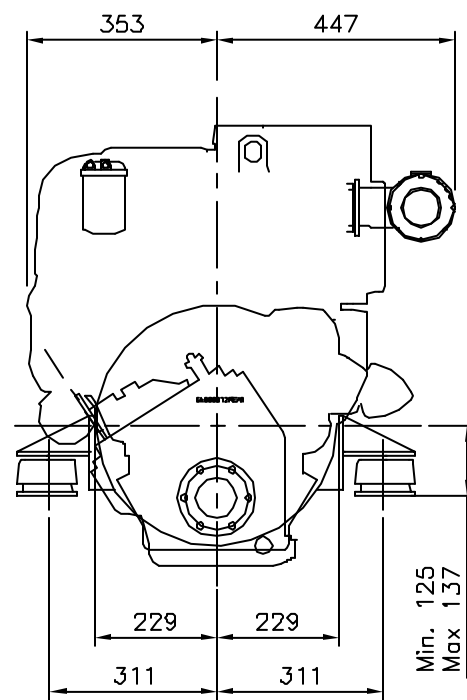

BAKFRA

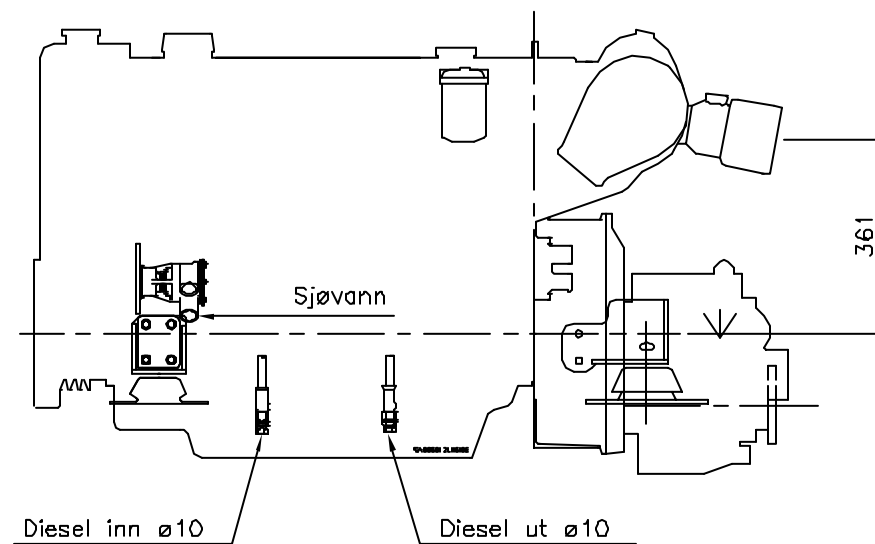

VENSTRE SIDE

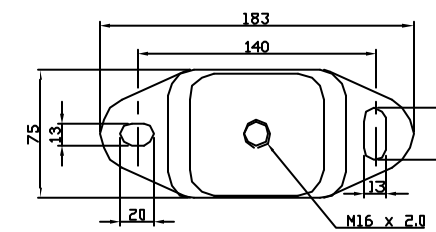

FREMRE GUMMIDEMPER

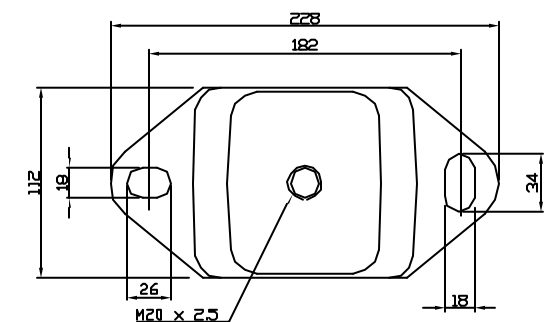

BAKRE GUMMIDEMPER

Vekt på hver demper:

Foran: 186kg / demper

Bak: 195kg / demper

Total vekt: 762kg

Antall	Pos. nr.	Navn, type, dimensjon	Tegning Produsent	Målestokk	Materiale	kg pr. stk.
Dato	14.10.96	Konstr./Tegner M.W.F.	Godkjent	1:10	UNIPOWER	
Dato nr.				Etablning for: Etablning av:		
PERKINS SABRE M 265Ti & M300Ti m. PRM 1000 D (601 D)				Tegnr.: A2-0043 A		
Henvendings:		Beregning:				
Tegnet på AUTOCAD av: Tegne & DAK Tjeneste. Tlf. 911 01 929. tegnedak@online.no.						