

FORFRA

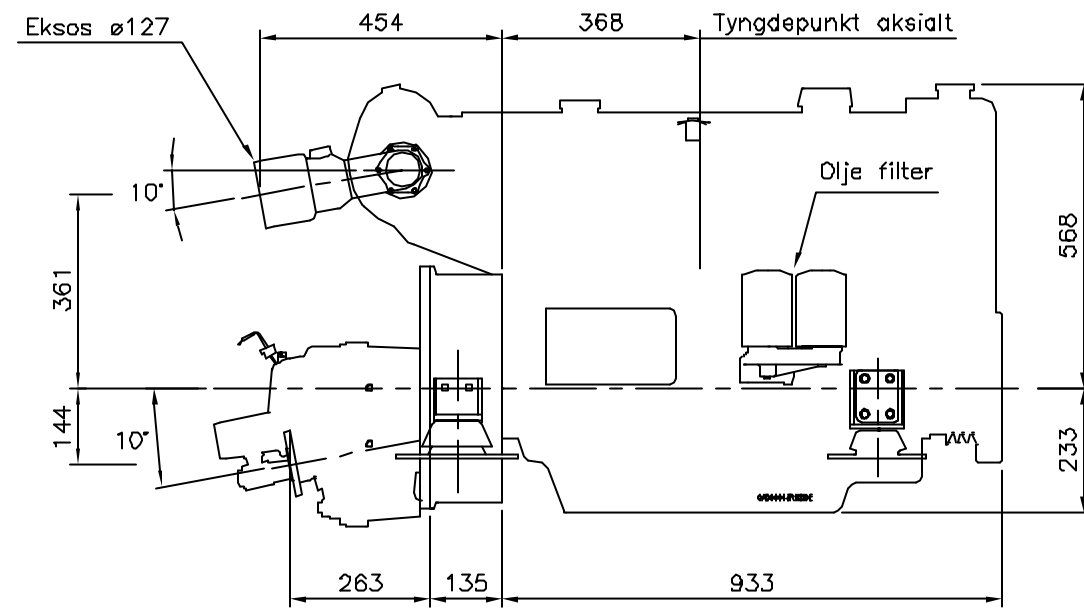

HØYRE SIDE

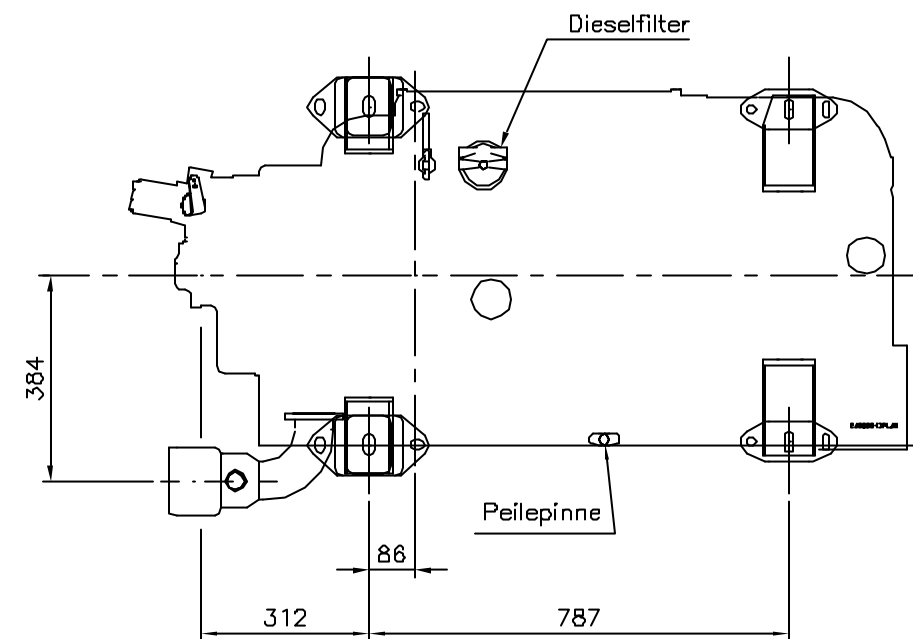

OVENFRA

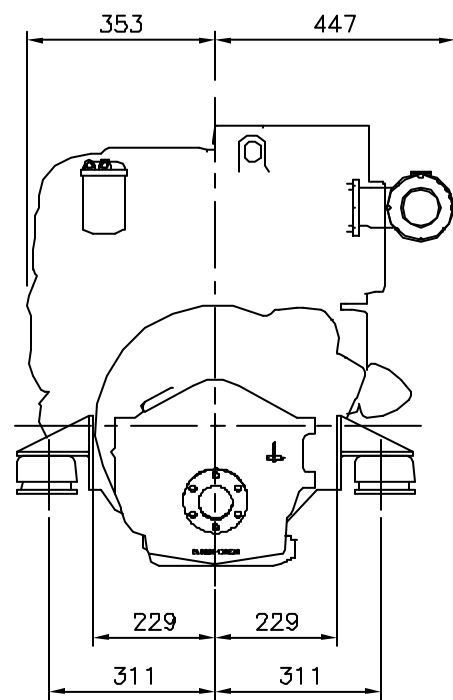

BAKFRA

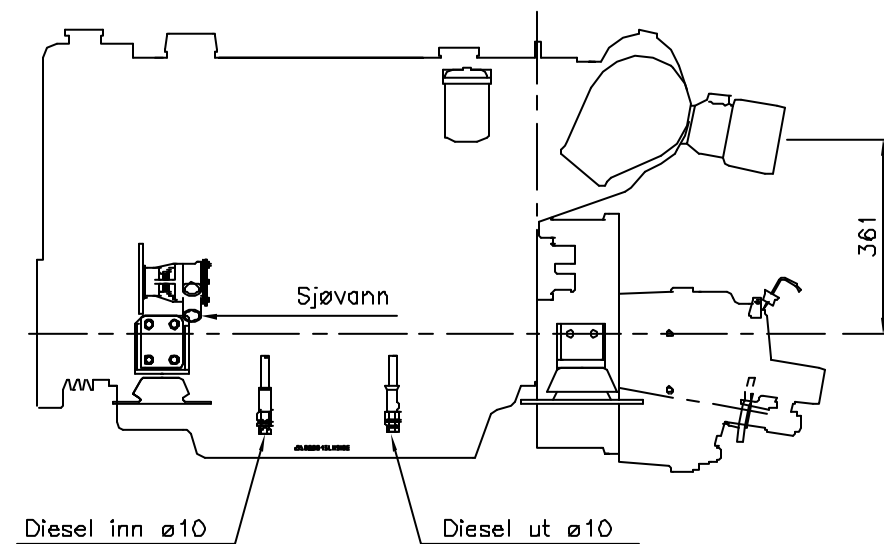

VENSTRE SIDE

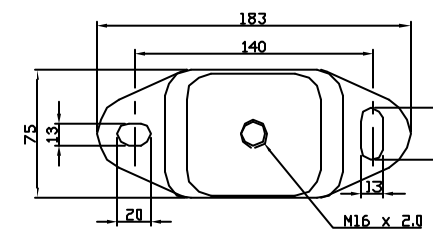

FREMRE GUMMIDEMPER

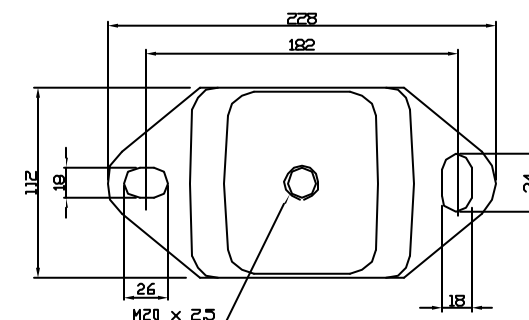

BAKRE GUMMIDEMPER

Vekt på hver demper:

Foran: 183kg / demper

Bak: 134,3kg / demper

Total vekt: 635,6kg

Antall	Pos. nr.	Navn, type, dimensjon	Tegning	Materiale	kg pr. stk.
Dato	14.10.96	Konstr./Tegner M.W.F.	Godkjent	Målestokk	UNIPOWER
Del nr.				1:10	
PERKINS SABRE M 265Ti & M300Ti m. MPM 220 A				Erstatning for:	Erstatning av:
				Tegnr.:	A2-0044
Henvendings:		Beregning:			
Tegnet på AUTOCAD av: Tegne & DAK Tjeneste. Tlf. 911 01 929. tegnedak@online.no.					