

FORFRA

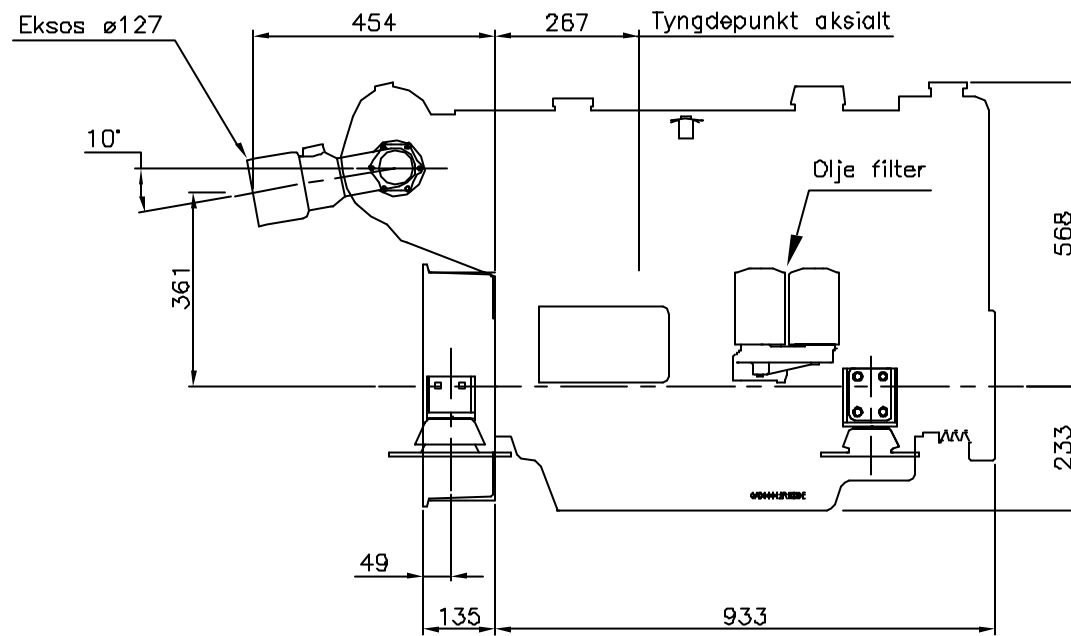

HØYRE SIDE

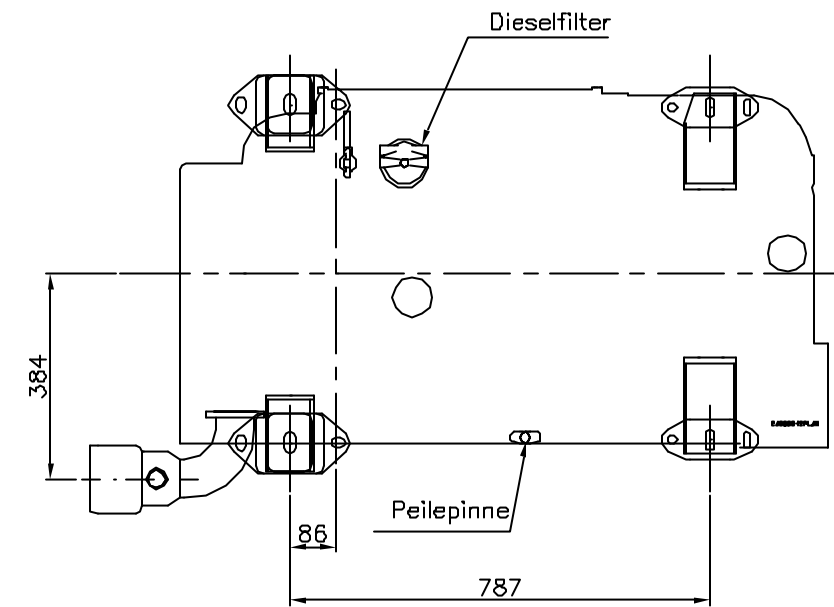

OVENFRA

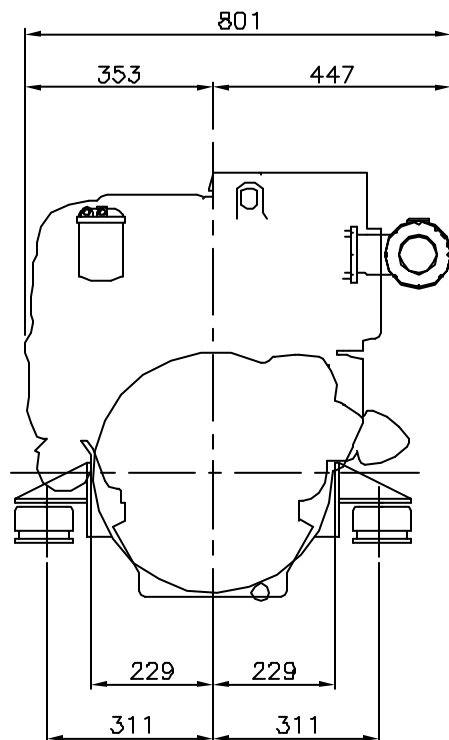

BAKFRA

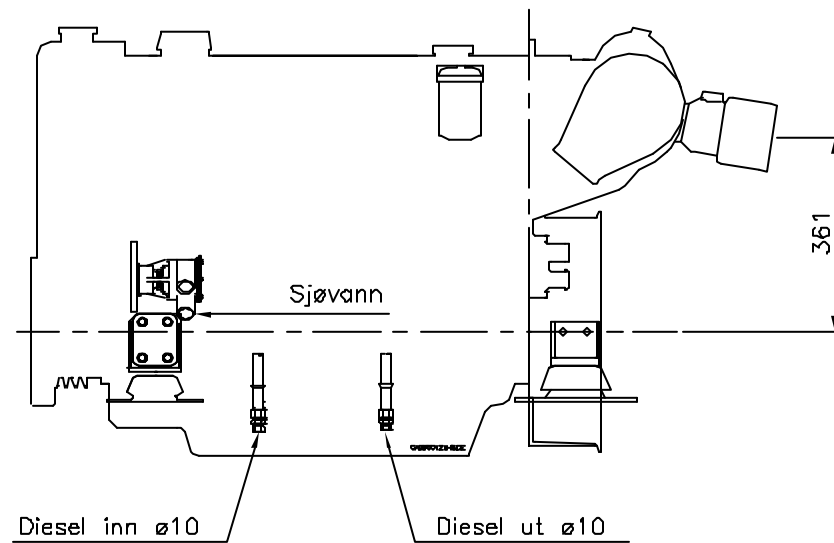

VENSTRE SIDE

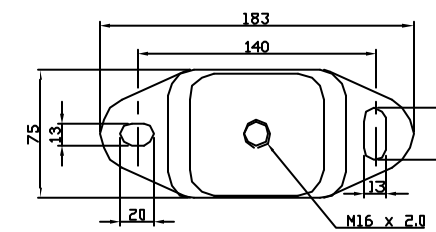

FREMRE GUMMIDEMPER

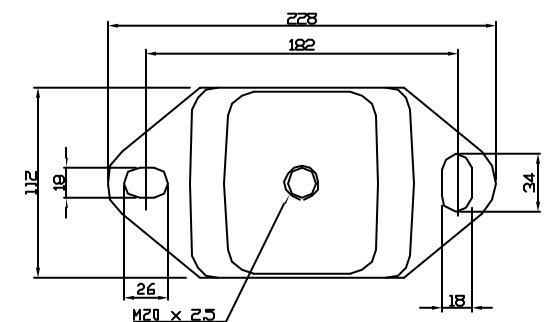

BAKRE GUMMIDEMPER

Vekt på hver demper:

Foran: 186kg / demper

Bak: 195kg / demper

Total vekt: 762kg

Antall	Pos. nr.	Navn, type, dimensjon	Tegning	Materiale	kg pr. stk.
Dato	23.11.2001	Konstr./Tegner M.W.F.	Godkjent	Målestokk	UNIPOWER
Dato				1:10	
PERKINS SABRE M 265Ti & M300Ti				Erstatning for:	Erstatning av:
				Tegning nr.:	A2-0103 A
Henvendings:		Beregning:			
Tegnet på AUTOCAD av: Tegne & DAK Tjeneste. Tlf. 911 01 929. tegnedak@online.no.					