

HØYRE SIDE

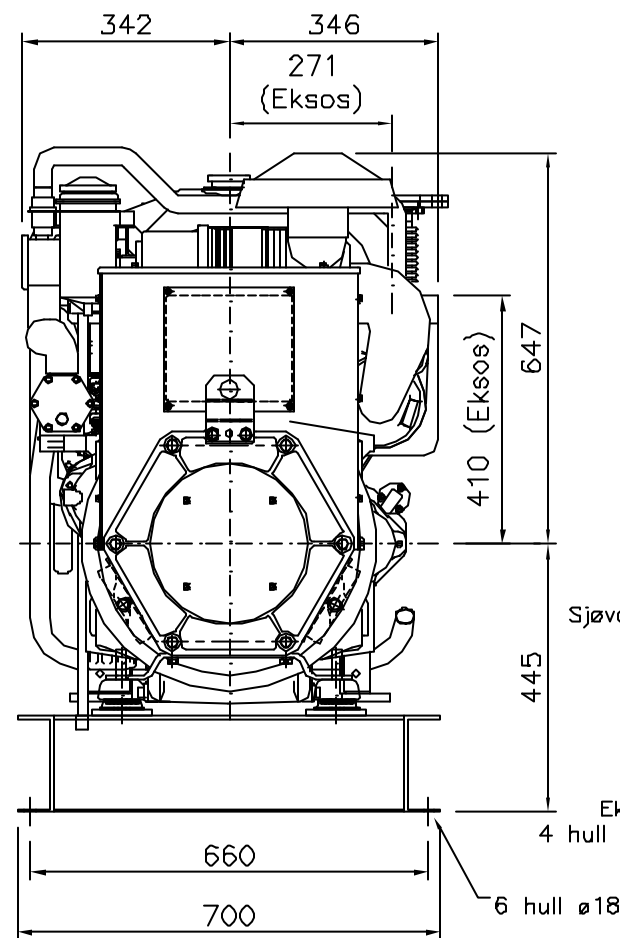

BAK

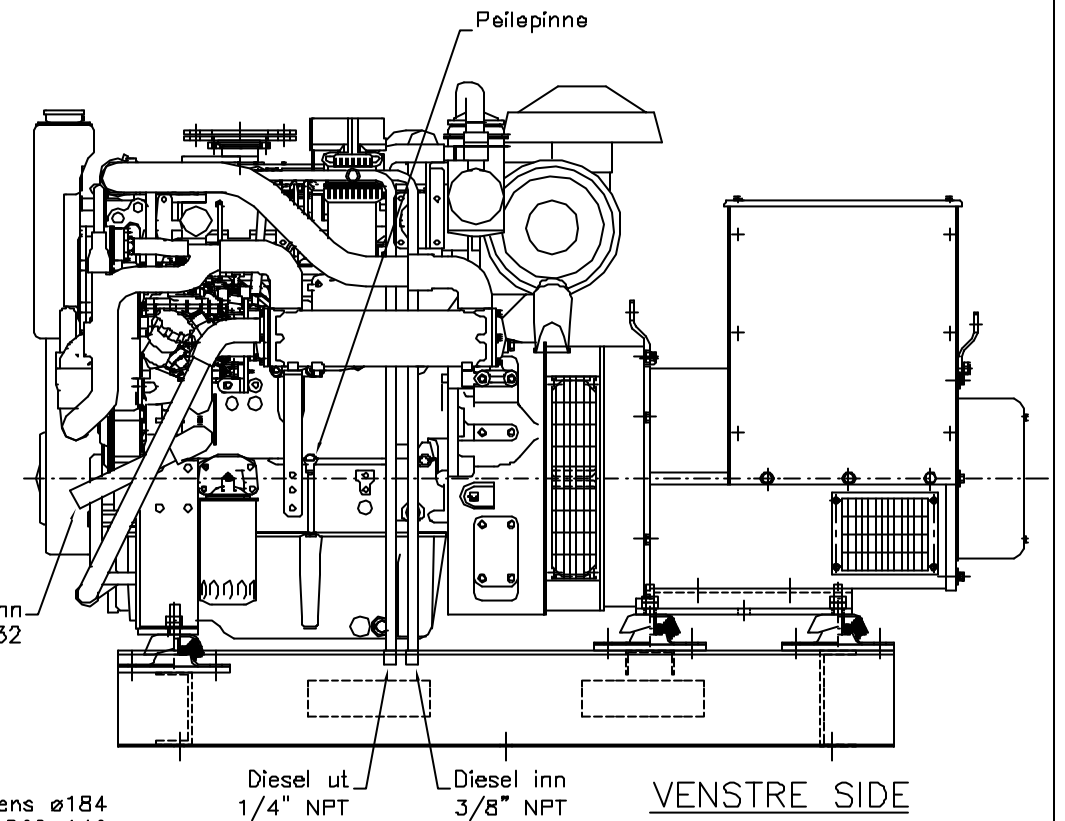

VENSTRE SIDE

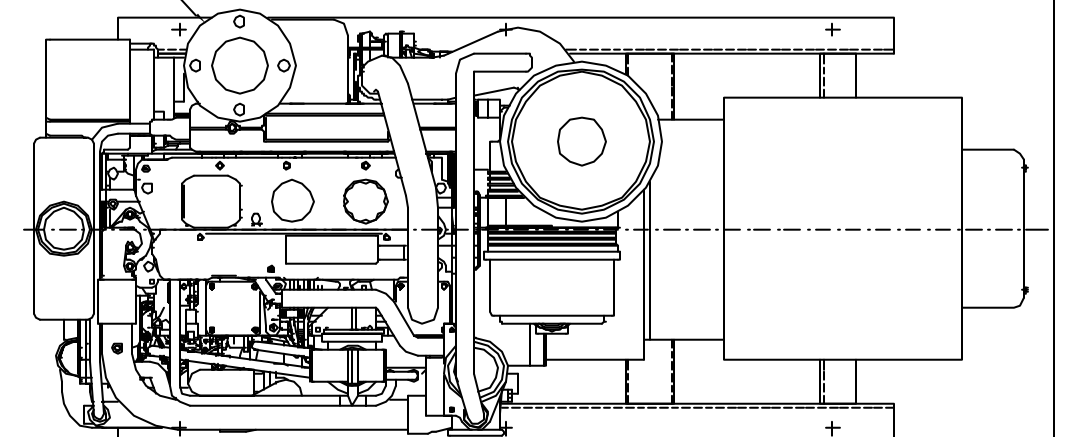

OVENFRA

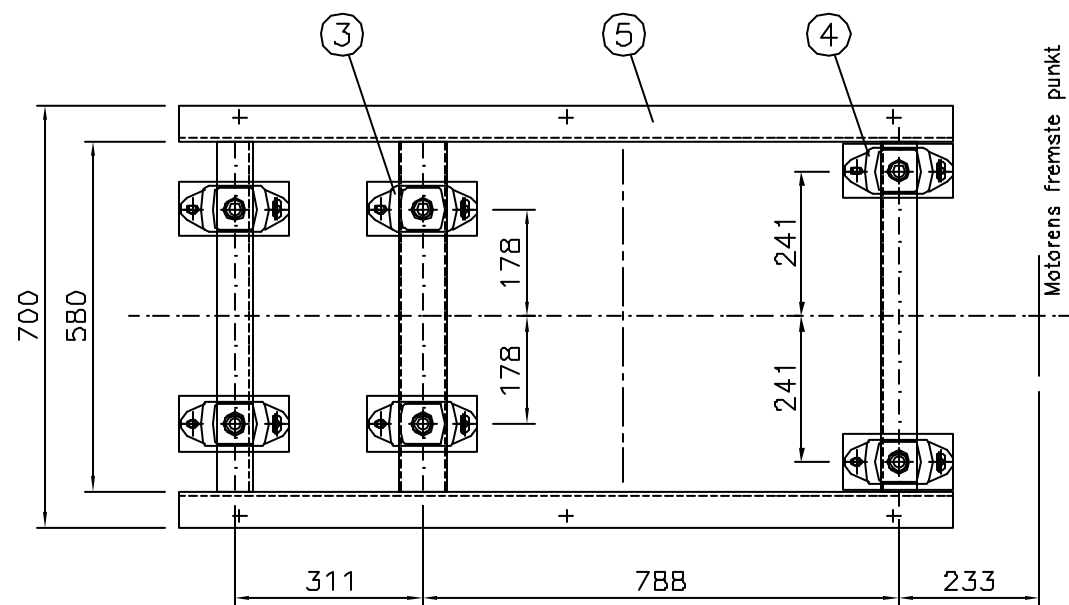
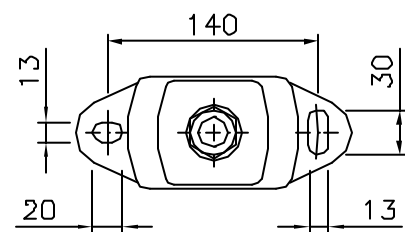

PLAN RAMME MED DEMPERE

Motørens fremste punkt

Sjøvann ut ø32

FRONT

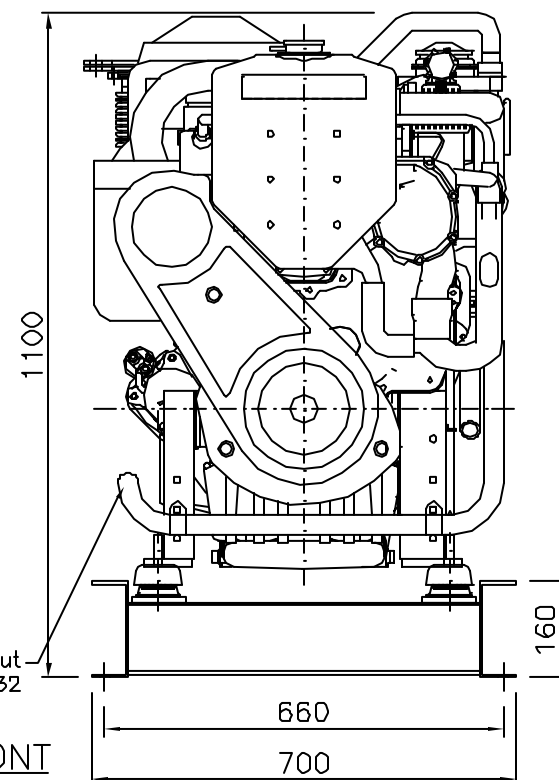

Antall	Pos. nr.	Navn, type, dimensjon	Tegning Produktid.	Materiale	kg pr. stk.
1	6	Kompensator	A4-0025		
1	5	Ramme	A3-022B	Kaldvalset stål	
2	4	Gummidemper, Front motor	A4-0013		PC140-55
4	3	Gummidemper, Generator	A4-0013		PC140-45
1	2	Stamford UCM224F			D23-2001
1	1	Perkins 4.4TGM	A3-0231		

Data	01.02.2006	Konstr./Tegner	M.W.F.	Godkjent	Målestokk	1:12,5	UNIPOWER
Dele nr.							
PERKINS 4.4TGM STAMFORD UCM 224F, 1-LAGRET MED RAMME						Erstatning for:	Erstatning av:
Henviing:						Beregning:	Tegn.nr.: A3-0225 B