

HØYRE SIDE

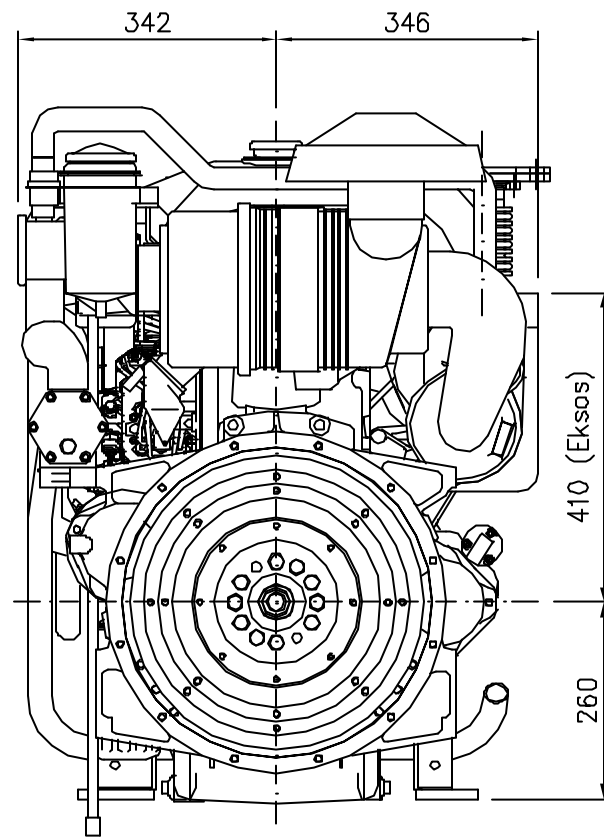

BAK

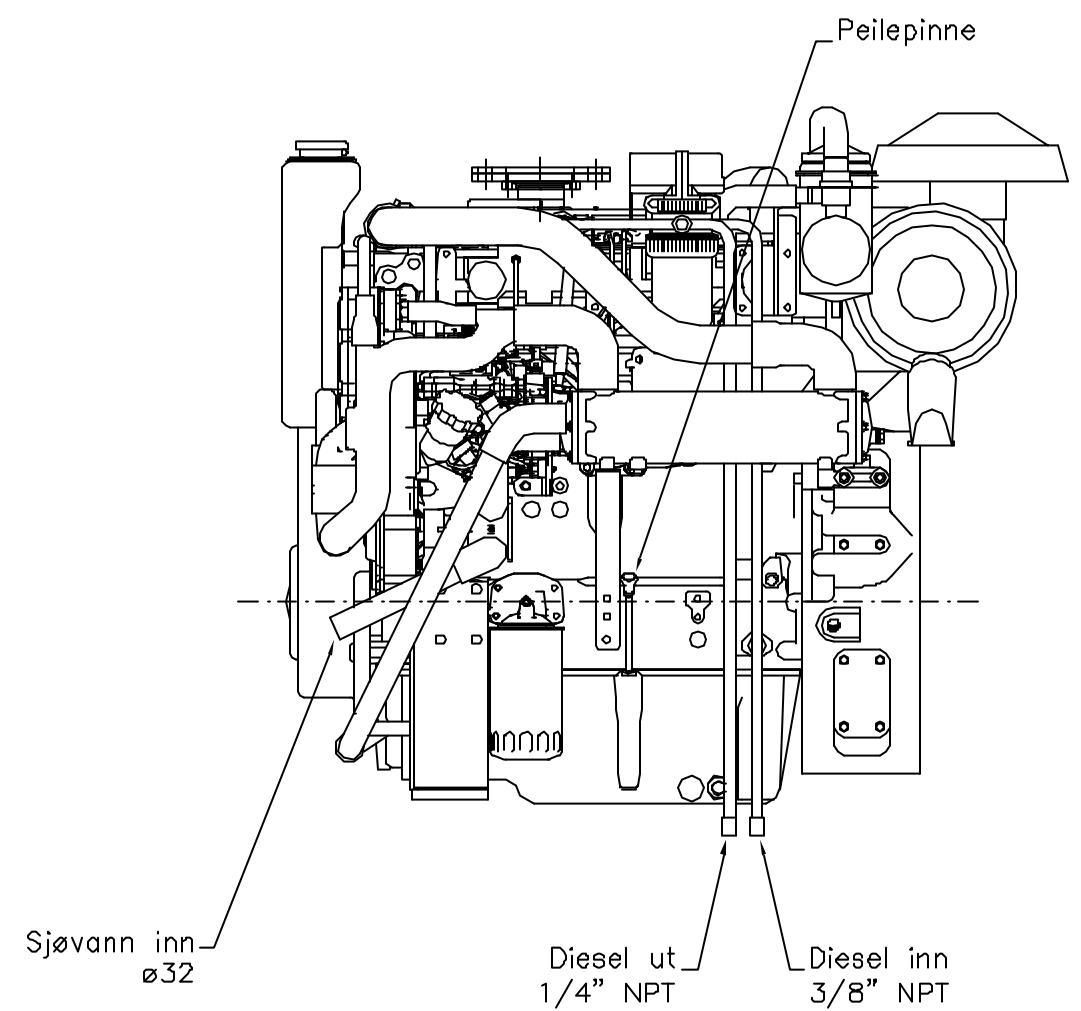

VENSTRE SIDE

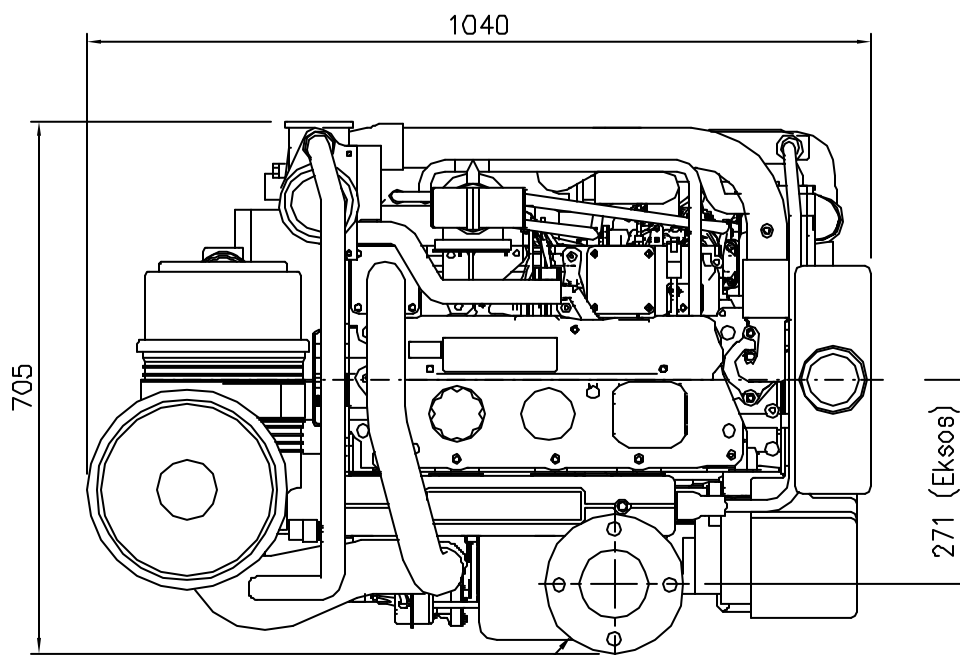

OVENFRA

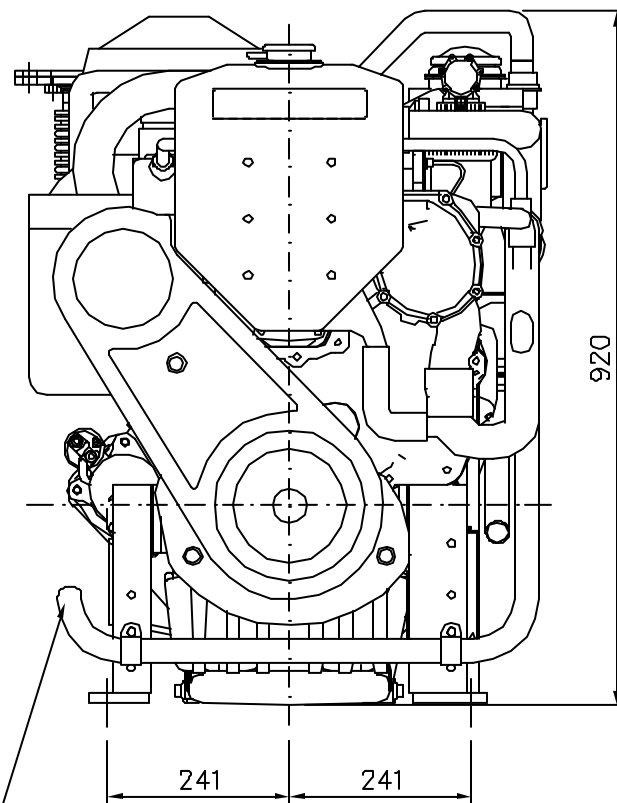

FRONT

1	4	Kompensator	A4-0025			
2	3	Gummidemper, Front motor	A4-0013			PC140-55
4	2	Gummidemper, Generator	A4-0013			PC140-45
1	1	Perkins 4.4TGM				
Antall	Pos. nr.	Navn, type, dimensjon	Tegning Produktid.	Materiale	kg pr. stk.	
Data		Konstr./Tegner	Godkjent	Målestokk	UNIPOWER	
02.02.2006		M.W.F.		1:10		
Dele nr.				A3-0231 A		
PERKINS 4.4TGM				Erstatning for:		Erstatning av:
				Tegn.nr.:		
				A3-0231 A		
Henvening:			Beregning:			
Tegnet på AUTOCAD av: Tegne & DAK Tjeneste. Tlf. 911 01 929. tegnedak@online.no.						