

HØYRE SIDE

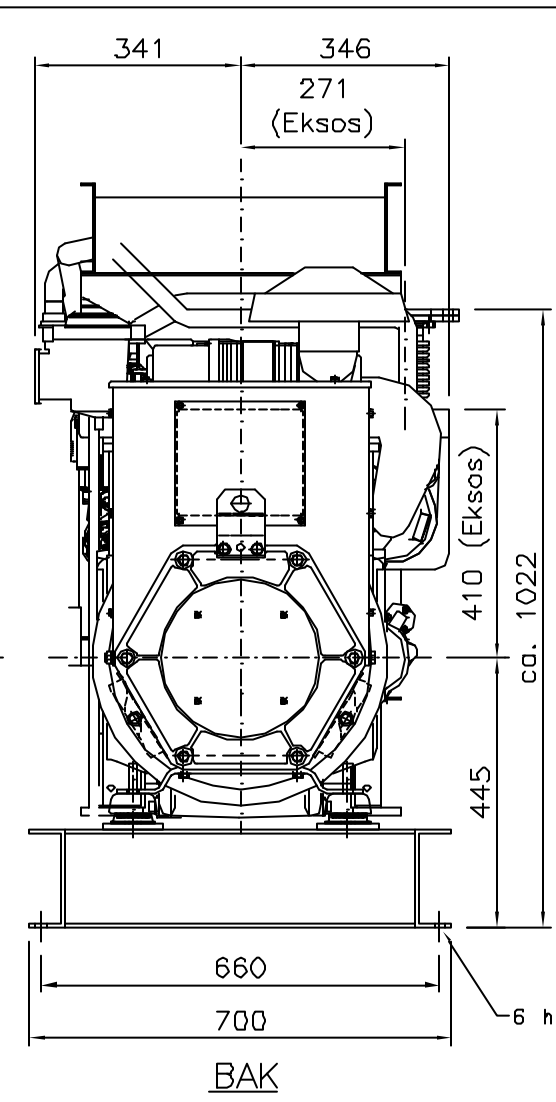

BAK

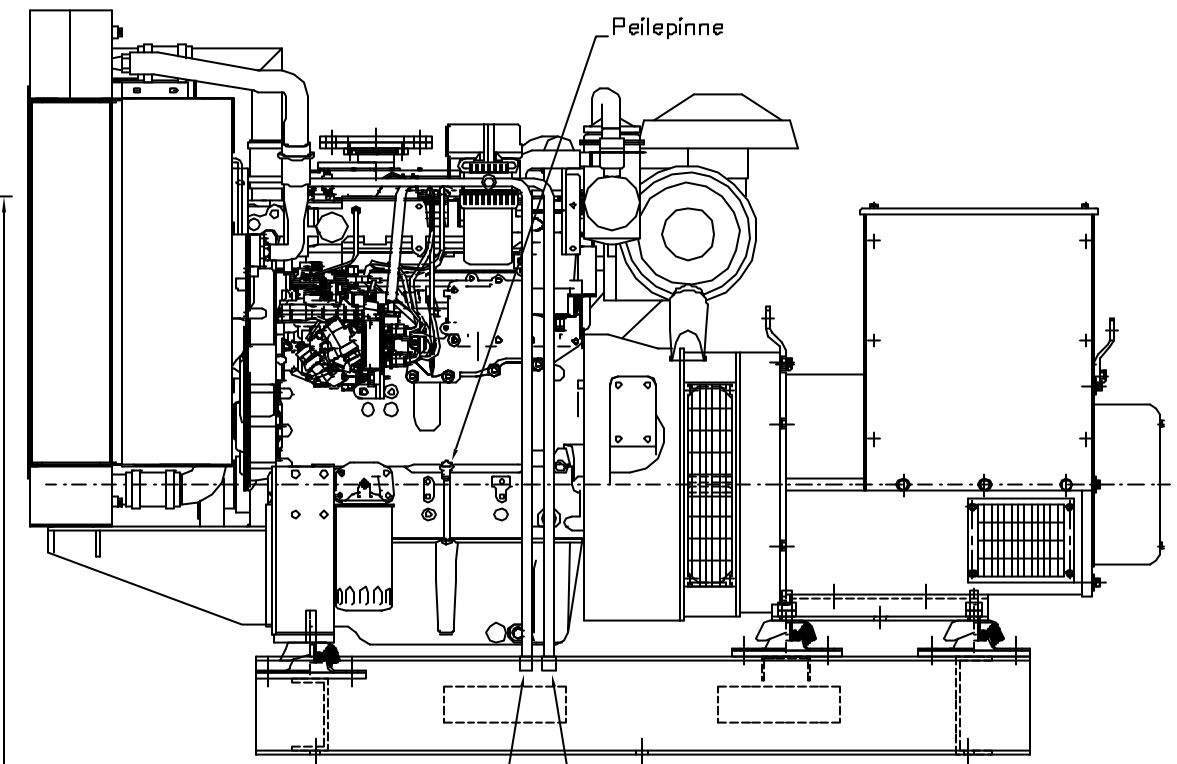

VENSTRE SIDE

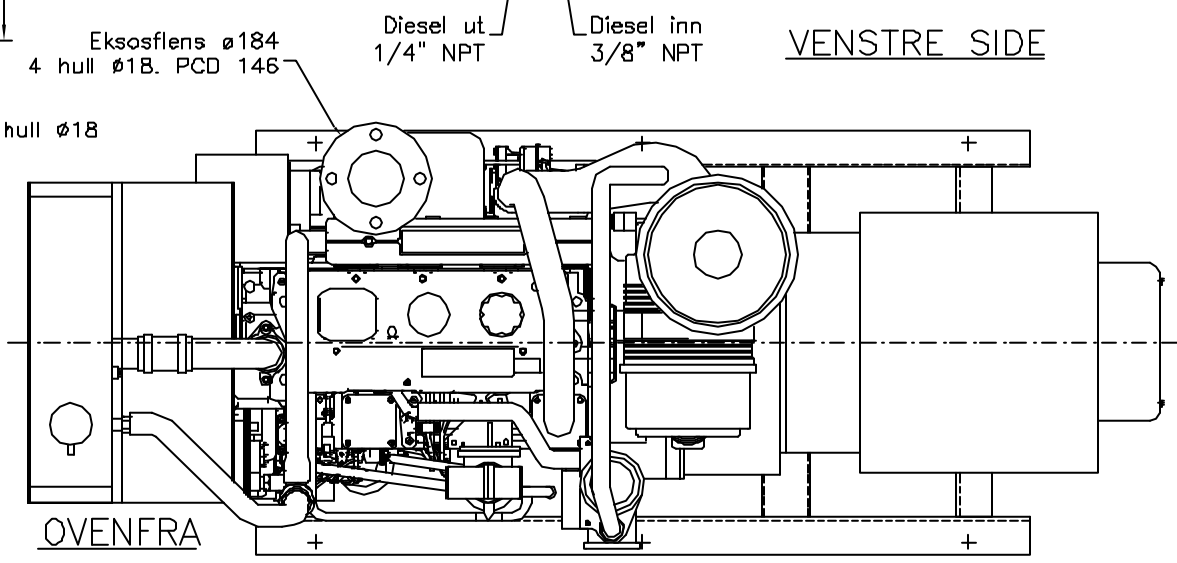

OVENFRA

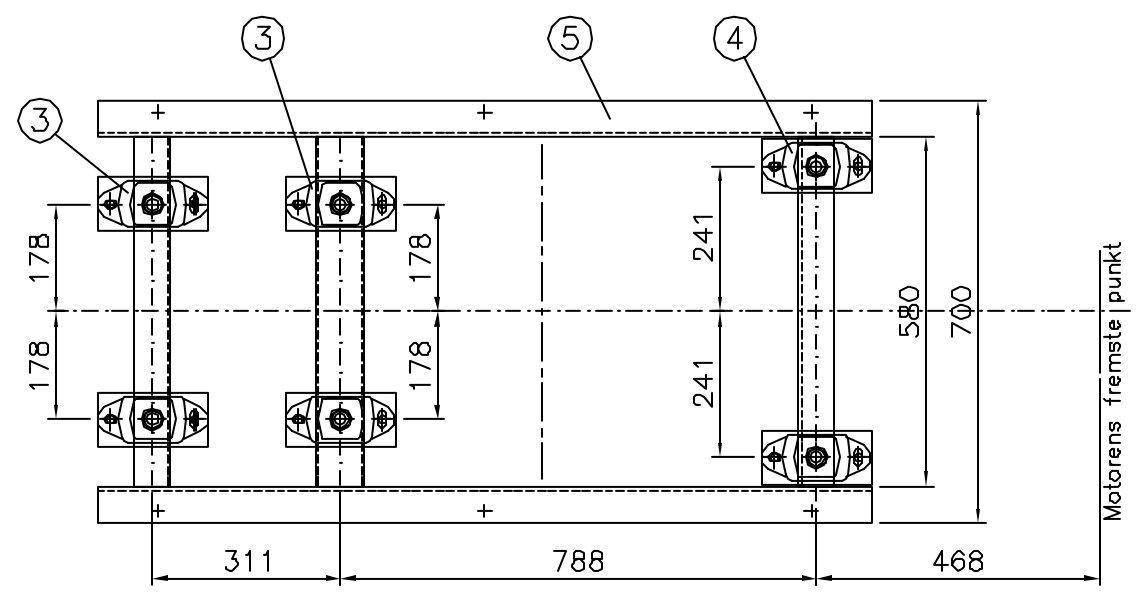

PLAN RAMME MED DEMPERE

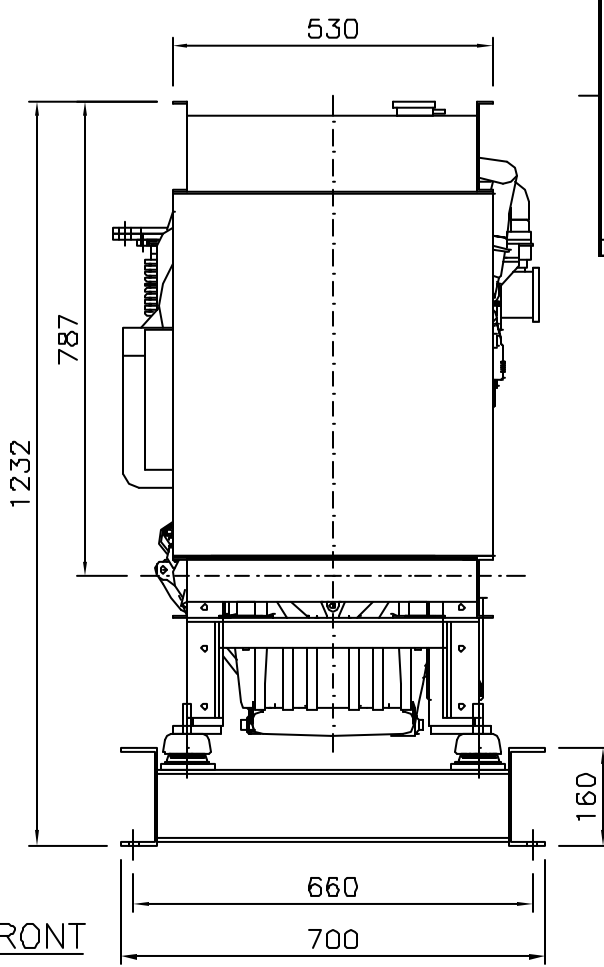

FRONT

Antall	Pos. nr.	Navn, type, dimensjon	Tegning Produktid.	Materiale	kg pr. stk.
1	6	Kompensator	A4-0025		
1	5	Ramme	A3-0228		
2	4	Gummidemper, Front motor	A4-0013		PC140-55
4	3	Gummidemper, Generator	A4-0013		PC140-45
1	2	Stamford UCM224F			D23-2001
1	1	Perkins 4.4TGM	-		Doc7436-2-06

Data	05.04.2006	Konstr./Tegnør	M.W.F.	Godkjent	Målestokk	1:12,5	UNIPower
Dele nr.							
PERKINS 4.4TGM m. RADIATOR STAMFORD UCM 224F, 1-LAGRET MED RAMME						Erstatning for:	Erstatning av:
Henvening:						Beregning:	Tegn.nr.: A3-0240 A
Tegnet på AUTOCAD av: Tegne & DAK Tjeneste. Tlf. 911 01 929. tegnedak@online.no.							