

FRONT

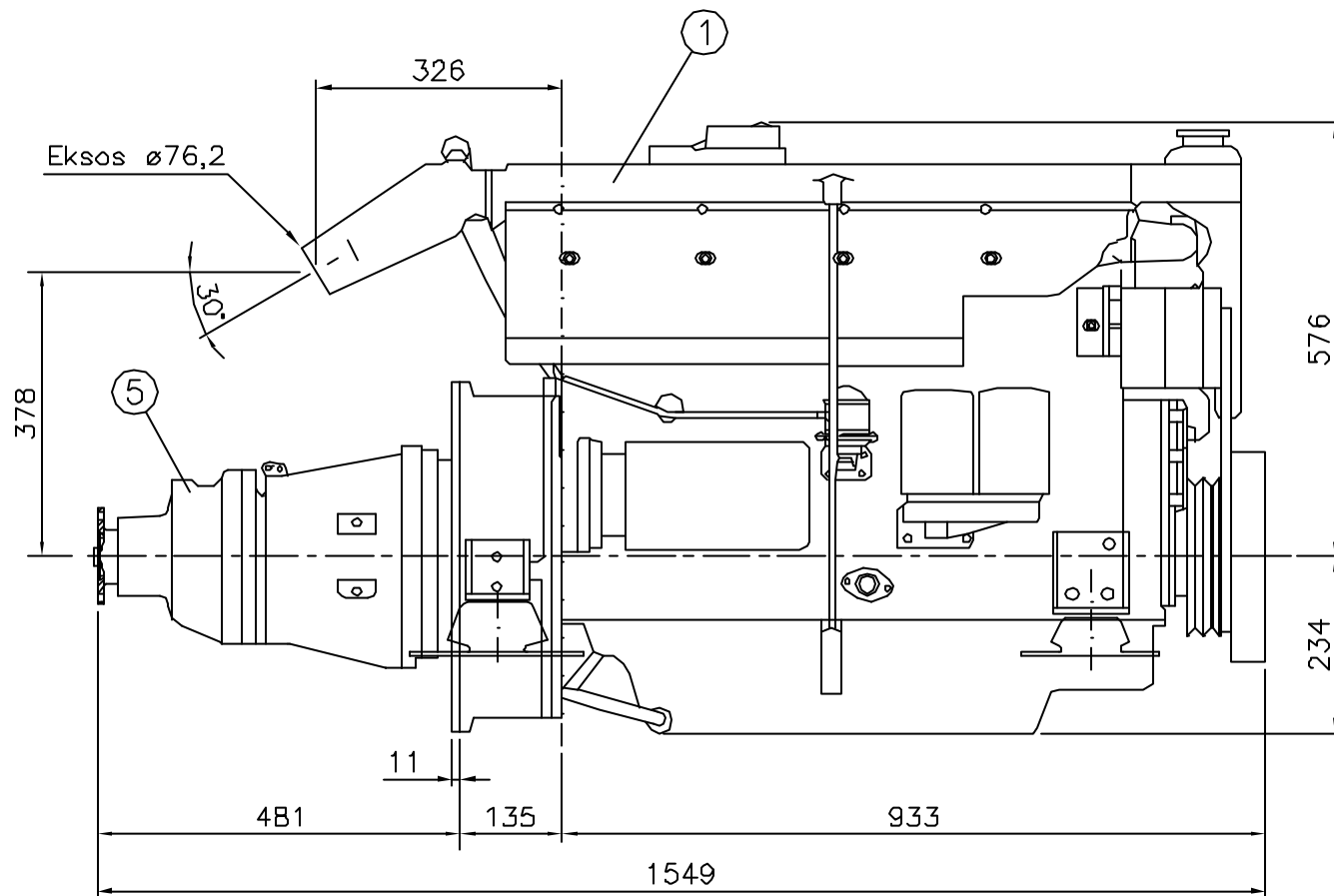

HØYRE SIDE

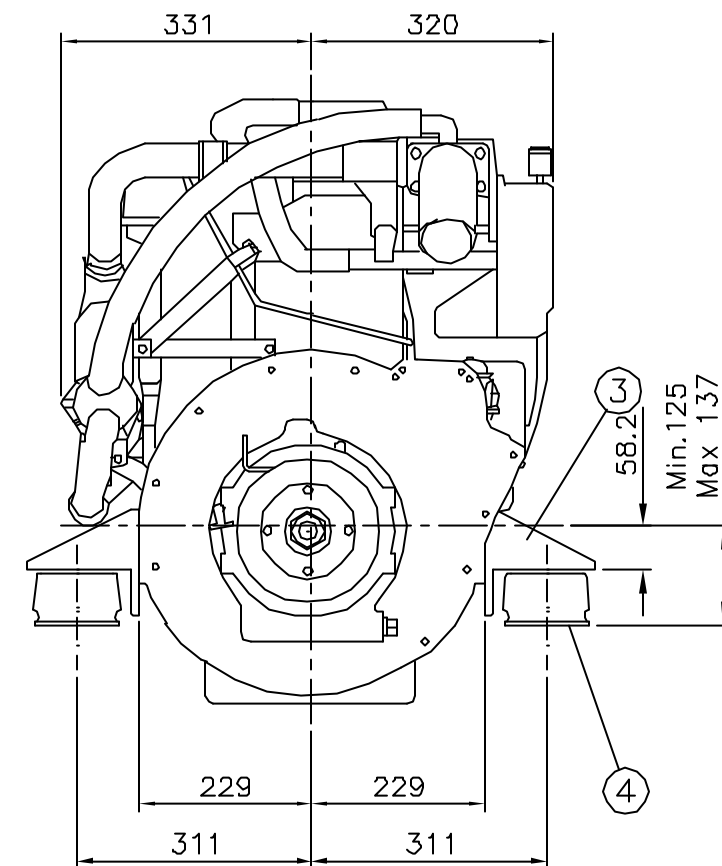

BAK

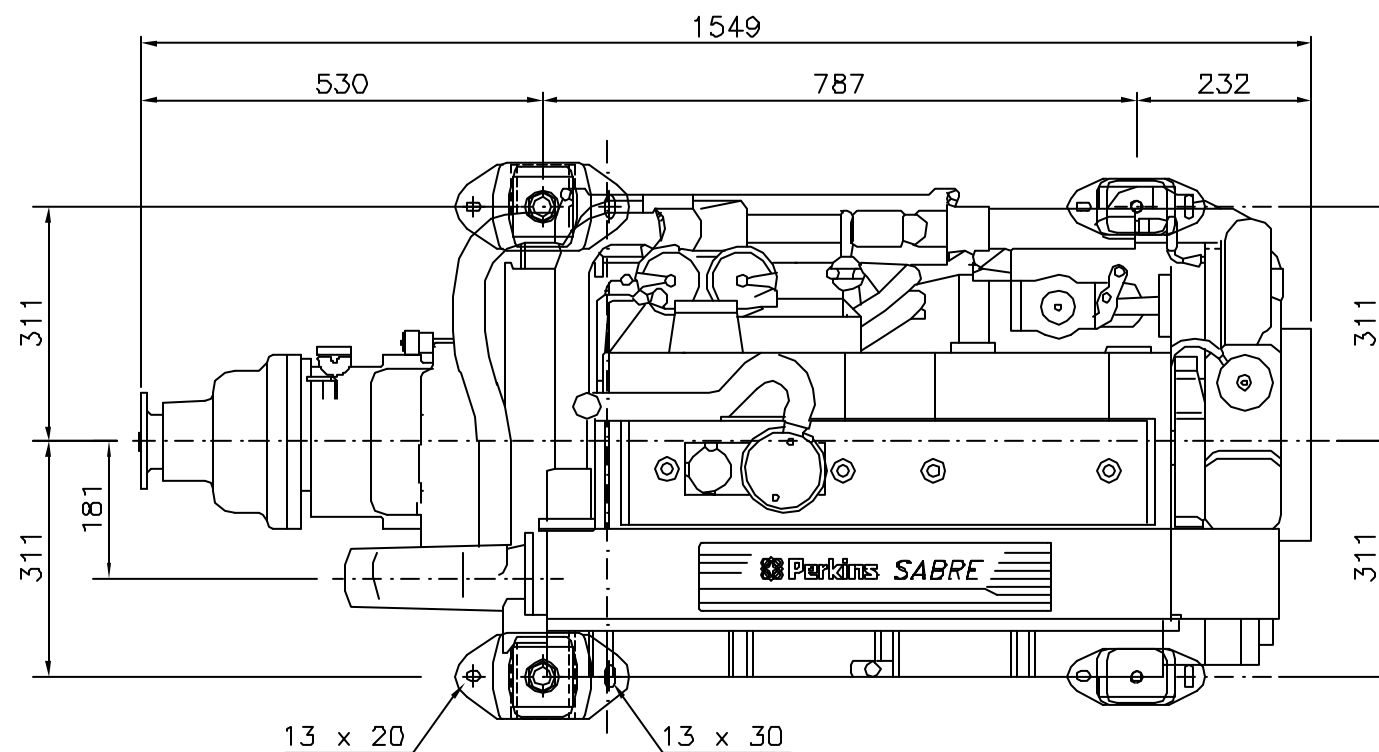

OVENFRA

1	5	Borg Warner 72CR				
4	4	Gummidemper		SAB 102		
2	3	Braketter (bak)		SAB 070		
2	2	Braketter (front)		SAB 100		
1	1	Perkins Sabre M130/135				
Antal	Pos. nr.	Navn, type, dimensjon	Tegning Produktid.	Materiale	kg pr. stk.	

Dato	17.08.2007	Konstr./Tegner	M.W.F.	Godkjent	Målestokk	UNIPOWER
Dele nr.					1:10	
PERKINS SABRE M130C VARMEVEKSLERKJØLT. VÅTEKSOS. m./ BORG WARNER 72CR					Erstatning for:	Erstatning av:
Henvising:					Beregning:	Tegn.nr.: A3-0269

Tegnet på AUTOCAD av: Tegne & DAK Tjeneste. Tlf. 911 01 929. tegnedak@online.no.