

FRONT

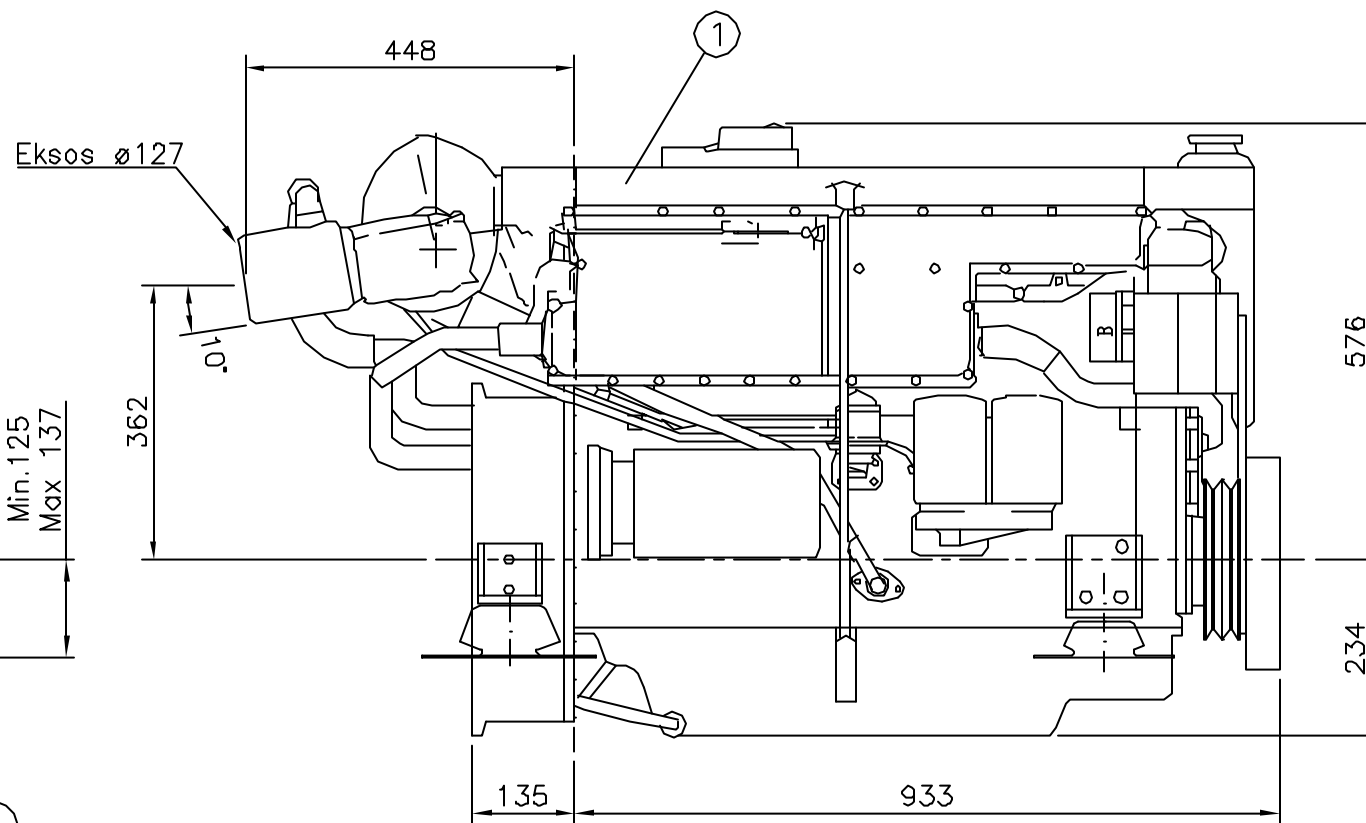

HØYRE SIDE

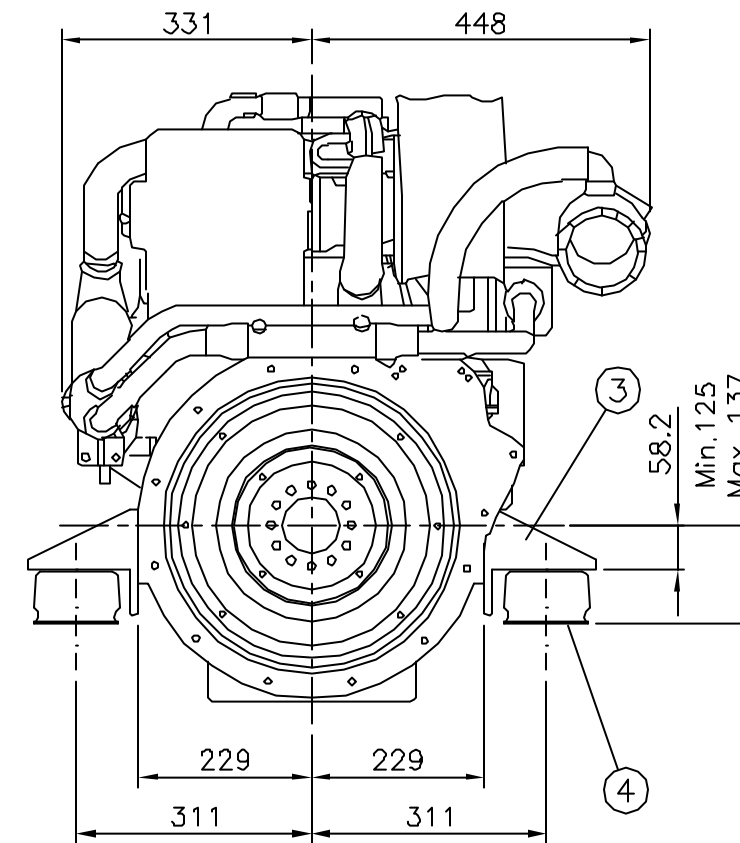

BAK

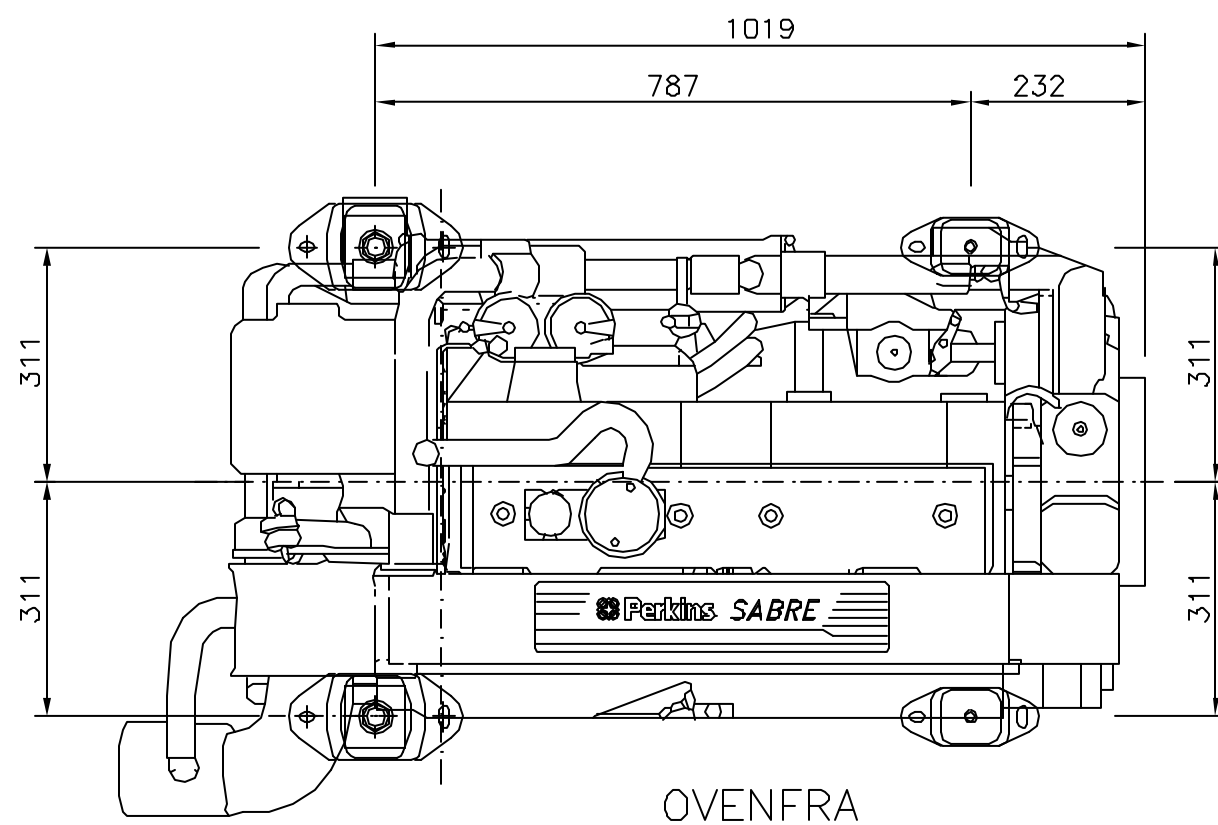

OVENFRA

4	4	Gummidemper		SAB 102		
2	3	Braketter (bak)		SAB 100		
2	2	Braketter (front)		SAB 100		
1	1	Perkins Sabre M185-225				
Antall	Pos. nr.	Navn, type, dimensjon	Tegning Produkdtd.	Materiale	kg pr. stk.	
Dato		Konstr./Tegner	Godkjent	Målestakk		
7.7.94		M.W.F.		1 : 10		
Dete nr.				UNIPOWER		
PERKINS SABRE M185-215 VARMEVEKSLERKJØLT. VÅTEKSOS.				Erstatning for:		Erstatning av:
				Tegn.nr.:		A3-0011 A
Henviøning:			Beregning:			
Tegnet p& AUTOCAD av: Tegne & DAK Tjeneste. Tlf. 911 01 929. tegnedak@online.no.						