

FRONT

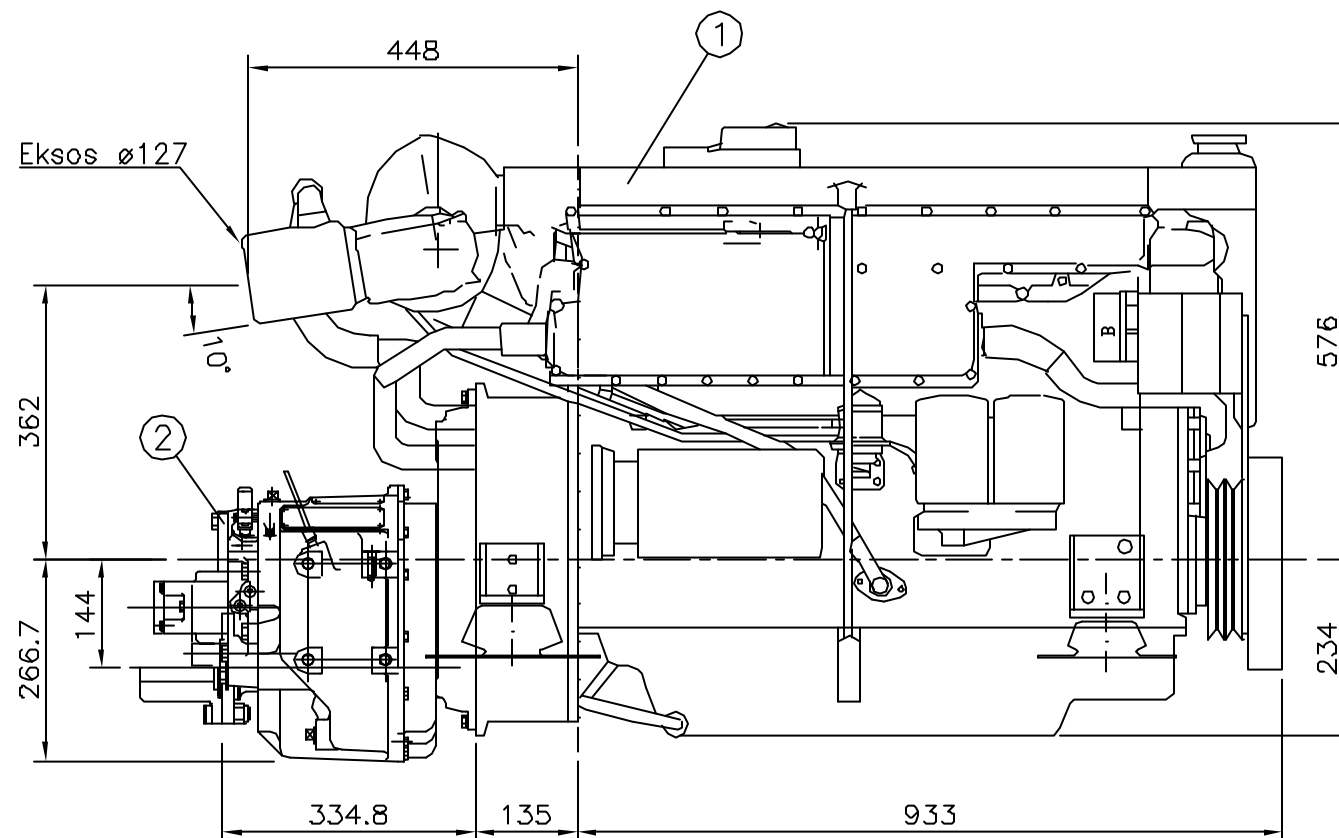

HØYRE SIDE

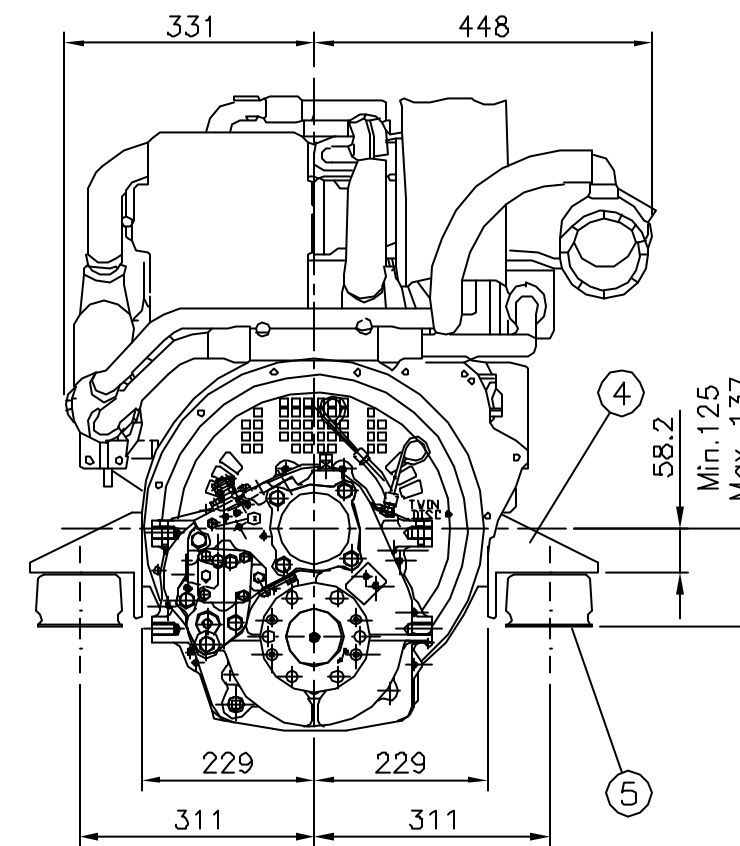

BAK

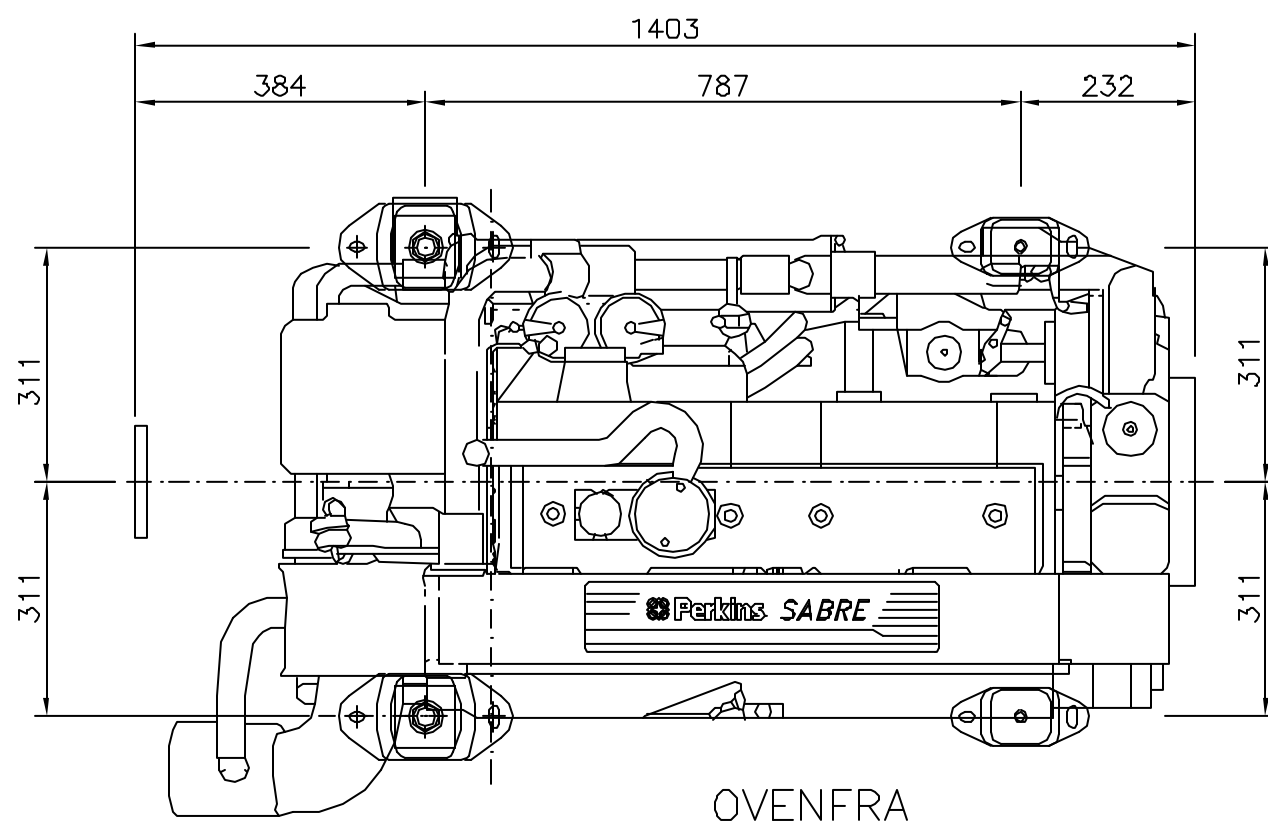

OVENFRA

4	5	Gummidemper		SAB 102		
2	4	Braketter (bak)		SAB 100		
2	3	Braketter (front)		SAB 100		
1	2	Twin Disc MG 5061				
1	1	Perkins Sabre M185C				
Antall	Pos. nr.	Navn, type, dimensjon	Tegning Produktid.	Materiale	kg pr. stk.	
Dato		Konstr./Tegner	Godkjent	Målestakk		
02.04.2004		M.W.F.		1:10		
Dete nr.				UNIPOWER		
PERKINS SABRE M185C VARMEVEKSLERKJØLT. VÅTEKSOS. m/ TWIN DISC MG 5061				Erstatning for:		Erstatning av:
				Tegn.nr.:		A3-0183
Henviing:			Beregning:			
Tegnet på AUTOCAD av: Tegne & DAK Tjeneste. Tlf. 911 01 929. tegnedak@online.no.						